

Motion Control Basics

By John Mazurkiewicz
Baldor Electric

Here are easy to follow equations for determining drive mechanics friction and inertia for any electromechanical positioning application. Part 2 describes how to determine motor and control requirements.

Part 1 – Drive mechanics

The first step in determining the requirements of a motion control system is to analyze the mechanics including friction and inertia of the load to be positioned. Load friction can easily be determined either by estimating or by simply measuring with a torque wrench.

Inertia the resistance of an object to accelerate or decelerate defines the torque required to accelerate a load from one speed to another, but it excludes frictional forces. Inertia is calculated by analyzing the mechanical linkage system that is to be moved. Such systems are categorized as one of four basic drive designs: direct, gear, tangential, or leadscrew.

In the following analyses of mechanical linkage systems, the equations reflect the load parameters back to the motor shaft. A determination of what the motor “sees” is necessary for selecting both motor and control.

Cylinder inertia

The inertia of a cylinder can be calculated based on its weight and radius, or its density, radius, and length.

- (1) $J = \frac{WR^2}{2g}$ Inertia for solid cylinder based on weight and radius.
- (2) $J = \frac{\pi L \rho R^4}{2g}$ Inertia for solid cylinder based on density, radius, and length.
- (3) $J = \frac{W}{2g} (R_o^2 + R_i^2)$ Inertia for hollow cylinder based on weight and radius.
- (4) $J = \frac{\pi L \rho}{2g} (R_o^4 - R_i^4)$ Inertia for hollow cylinder based on density, radius, and length.

With these equations, the inertia of mechanical components (such as shafts, gears, drive rollers) can be calculated. Then, the load inertia and friction are reflected through the mechanical linkage system to determine motor requirements.

Example: If a cylinder is a leadscrew with a radius of 0.312 in. and a length of 22 in., the inertia can be calculated by using Table 1 and substituting in Equation (2):

$$J = \frac{\pi L \rho R^4}{2g} = \frac{(\pi \times 22 \times 0.28 \times 0.312)^4}{2 \times 386} = 0.000237 \text{ lb-in-sec}^2$$

Figure 1 – Solid cylinder

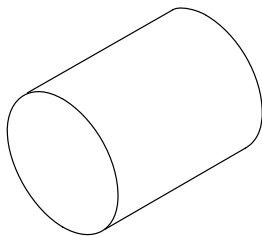

Figure 2 – Hollow cylinder

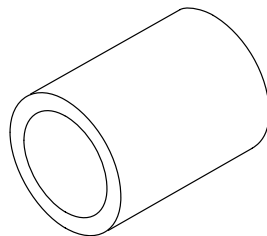

Table 1 – Material densities

Material	Density lb per in ³
Aluminum	0.096
Copper	0.322
Plastic	0.040
Steel	0.280
Wood	0.029

Direct drive

The simplest drive system is a direct drive, Figure 3. Because there are no mechanical linkages involved the load parameters are directly transmitted to the motor. The speed of the motor is the same as that of the load, so the load friction is the friction the motor must overcome, and load inertia is what the motor “sees.” Therefore, the total inertia is the load inertia plus the motor inertia.

$$(5) J_t = J_l + J_m$$

Nomenclature:

e	= Efficiency	N_m	= Number of motor gear teeth
F_l	= Load force, lb	ρ	= Density, lb/in ³
F_f	= Friction force, lb	P	= Pitch, rev/in.
F_{pf}	= Preload force, lb	R	= Radius, in.
g	= Gravitational constant, 386 in./sec ²	R_i	= Inner radius, in.
J	= Inertia, lb-in-sec ²	R_o	= Outer radius, in.
J_l	= Load Inertia, lb-in-sec ²	S_l	= Load speed, RPM
J_{ls}	= Leadscrew Inertia, lb-in-sec ²	S_m	= Motor speed, RPM
J_m	= Motor Inertia, lb-in-sec ²	T_f	= Friction torque, lb-in
J_p	= Pulley Inertia, lb-in-sec ²	T_l	= Load torque, lb-in
J_t	= Total Inertia, lb-in-sec ²	T_m	= Motor torque, lb-in
L	= Length, in.	T_r	= Torque reflected to motor, lb-in
μ	= Coefficient of friction	V_l	= Load velocity, imp
N	= Gear ratio	W	= Weight, lb
N_l	= Number of load gear teeth	W_{lb}	= Weight of load plus belt, lb

Figure 3 – Direct drive

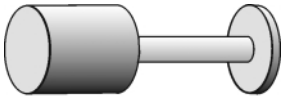

Figure 4 – Gear drive

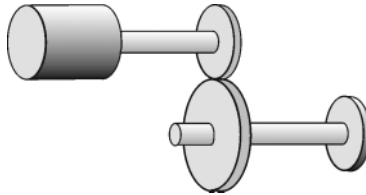
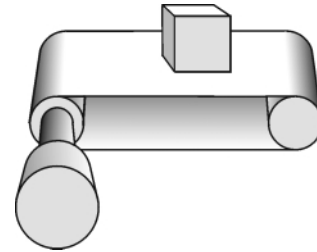

Figure 5 – Tangential drive



Gear drive

The mechanical linkage between the load and motor in a gear drive, Figure 4, requires reflecting the load parameters back to the motor shaft. As with any speed changing system, the load inertia reflected back to the motor is a squared function of the speed ratio.

Motor speed:

$$(6) S_m = S_l \times N \quad \text{or} \quad (7) S_m = \frac{S_l \times N_l}{N_m}$$

Motor torque:

$$(8) T_m = \frac{T_l}{N_e}$$

Reflected load inertia:

$$(9) J_r = \frac{J_l}{N^2}$$

Total inertia at motor:

$$(10) J_t = \frac{J_l}{N^2} + J_m$$

Example: To calculate the reflected inertia for a 6 lb, solid cylinder with a 4 in. diameter, connected through a 3:1 gear set, first use Equation (1) to determine the load inertia.

$$J = \frac{WR^2}{2g} = \frac{6 \times (2)^2}{2 \times 386} = 0.031 \text{ lb-in-sec}^2$$

To reflect this inertia through the gear set to the motor, substitute in Equation (9).

$$J_r = \frac{J_l}{N^2} = \frac{0.031}{3^2} = 0.0034 \text{ lb-in-sec}^2$$

For accuracy, the inertia of the gears should be included when determining total inertia. This value can be obtained from literature or calculated using the equations for the inertia of a cylinder. Gearing efficiencies should also be considered when calculating required torque values.

Tangential drive

Consisting of a timing belt and pulley, chain and sprocket, or rack and pinion, a tangential drive, Figure 5, also requires reflecting load parameters back to the motor shaft.

Motor speed:

$$(11) S_m = \frac{V_l}{2 \pi R}$$

Load torque:

$$(12) T_l = F_l R$$

Friction torque:

$$(13) T_f = F_f R$$

Load inertia:

$$(14) J = \frac{W_{lb} R^2}{g}$$

Total inertia:

$$(15) J_t = \frac{W_{lb} R^2}{g} + J_{p_1} + J_{p_2} + J_m$$

Example: A belt and pulley arrangement will be moving a weight of 10 lb. The pulleys are hollow cylinders, 5 lb each, with an outer radius of 2.5 in. and an inner radius of 2.3 in.

To calculate the inertial for a hollow, cylindrical pulley, substitute in Equation (3):

$$J_p = \frac{W}{2g} (R_o^2 + R_i^2) = \frac{5}{2 \times 286} (2.5^2 + 2.3^2) = 0.0747 \text{ lb-in-sec}^2$$

Substitute in Equation (14) to determine load inertia:

$$J_l = \frac{WR^2}{g} = \frac{10(2.5)^2}{386} = 0.1619 \text{ lb-in-sec}^2$$

Total inertia reflected to the motor shaft is the sum of the two pulley inertias plus the load inertia:

$$J = J_l + J_{p_1} + J_{p_2} = 0.1619 + 0.0747 + 0.0747 = 0.3113 \text{ lb-in-sec}^2$$

Also, the inertia of pulleys, sprockets or pinion gears must be included to determine the total inertia.

Leadscrew drive

Illustrated in Figure 6, a leadscrew drive also requires reflecting the load parameters back to the motor. Both the leadscrew and the load inertia have to be considered. If a leadscrew inertia is not readily available, the equation for a cylinder may be used. For precision positioning, the leadscrew may be preloaded to eliminate or reduce backlash. Such preload torque can be significant and must be included, as must leadscrew efficiency.

Figure 6 – Leadscrew

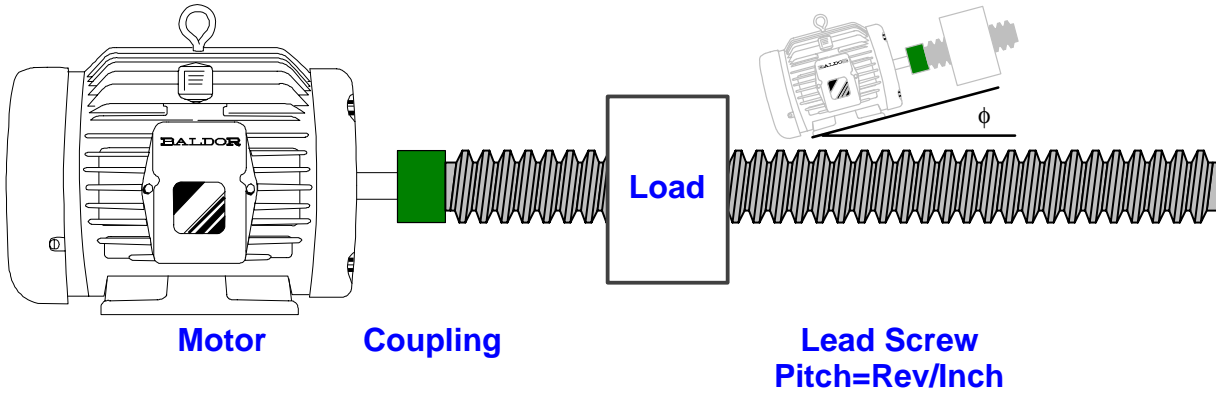

Motor speed:

$$(16) S_m = V_l \times P$$

Load torque reflected to motor:

$$(17) T_r = \frac{1}{2\pi} \frac{F_l}{Pe} + \frac{1}{2\pi} \frac{F_{pf}}{P} \times \mu$$

For typical values of leadscrew efficiency (e) and coefficient of friction (μ), see Tables 2 and 3.

Friction force:

$$(18) F_f = \mu \times W + \cos \phi + W \sin \phi$$

Friction torque:

$$(19) T_f = \frac{1}{2\pi} \frac{F_f}{Pe}$$

Total inertia:

$$(20) J_t = \frac{W}{g} \left(\frac{1}{2\pi P} \right)^2 + J_{ls} + J_m$$

Example: A 200 lb load is positioned by a 44 in. long leadscrew with a 0.5 in. radius and a 5 rev/in. pitch. The reflected load inertia is:

$$J_l = \frac{W}{g} \left(\frac{1}{2\pi P} \right)^2 = \frac{200}{386} \left(\frac{1}{2\pi \times 5} \right)^2 = 0.00052 \text{ lb-in-sec}^2$$

Leadscrew inertia is based on the equation for inertia of a cylinder:

$$J_{ls} = \frac{\pi L \rho R^4}{2g} = \frac{\pi \times 44 \times 0.28 \times 0.5^4}{2 \times 386} = 0.00313 \text{ lb-in-sec}^2$$

Total inertia to be connected to the motor shaft is:

$$J = J_l + J_{ls} = 0.00052 + 0.00313 = 0.00365 \text{ lb-in-sec}^2$$

Table 2 – Typical leadscrew efficiencies

Type	Efficiency
Ball nut	0.90
ACME (plastic nut)	0.65
ACME (metal nut)	0.40

Table 3 – Leadscrew coefficients of friction

Material	Coefficient
Steel on steel (dry)	0.58
Steel on steel (lubricated)	0.15
Teflon on steel	0.04
Ball bushing	0.003

Part 2 – Motor and Control Selection

In this part, we show you how to use the previous information on drive mechanics to easily determine the right motor and control for any electromechanical positioning application.

Once the mechanics of the application have been analyzed, and the friction and inertia of the load are known, the next step is to determine the torque levels required. Then, a motor can be sized to deliver the required torque and the control sized to power the motor. If friction and inertia are not properly determined, the motion system will either take too long to position the load, it will burn out, or it will be unnecessarily costly.

Motion control

In a basic motion control system, Figure 7, the load represents the mechanics being positioned. The load is coupled or connected through one of the mechanical linkages described in Part 1.

The motor may be a traditional PMDC servo motor, a vector motor, or a brushless servo motor. Motor starting, stopping and speed are dictated by the control (or amplifier), which takes a low level incoming command signal and amplifies it to a higher power level for driving the motor.

The programmable motion controller is the brain of the motion system. The motion controller is programmed to accomplish a specific task for a given application. This controller reads a feedback signal to monitor the position of the load. By comparing a preprogrammed, “desired” position with the feedback “actual” position, the controller can take action to minimize an error between the actual and desired load positions.

Figure 7 – Basic motion system

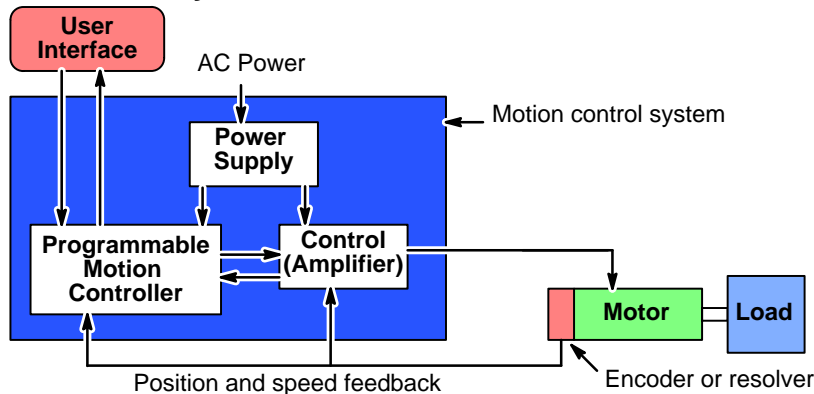

Nomenclature:

α_{acc} = Rotary acceleration, radians/sec ²	t_{acc} = Acceleration time, sec
I_{acc} = Current during acceleration, A	t_{dec} = Deceleration time, sec
I_{RMS} = Root-mean-squared current, A	t_{idle} = Idle time, sec
J_{ls} = Leadscrew inertia, lb-in-sec ²	t_{run} = Run time, sec
J_m = Motor inertia, lb-in-sec ²	T = Torque, lb-in
J_t = Total inertia (load plus motor), lb-in-sec ²	T_{acc} = Acceleration torque, lb-in
K_t = Torque constant, lb-in/A	T_{dec} = Deceleration torque, lb-in
P = Total power, W	T_f = Friction torque, lb-in
P_{del} = Power delivered to the load, W	T_{RMS} = Root-mean-squared torque, lb-in
P_{diss} = Power (heat) dissipated by the motor, W	T_{run} = Running torque, lb-in
R_m = Motor resistance, ohms	T_s = Stall torque, lb-in
S_m = Motor speed, RPM	

Move profile

A move profile defines the desired acceleration rate, run time, speed, and deceleration rate of the load. For example, suppose with a system at rest (time=0, Figure 8), the motion controller issues a command to the motor (through the control) to start motion. At t=0, with full power supply voltage and current applied, the motor has not yet started to move. At this instant, there is no feedback signal, but the error signal is large.

Figure 8 – Move profile

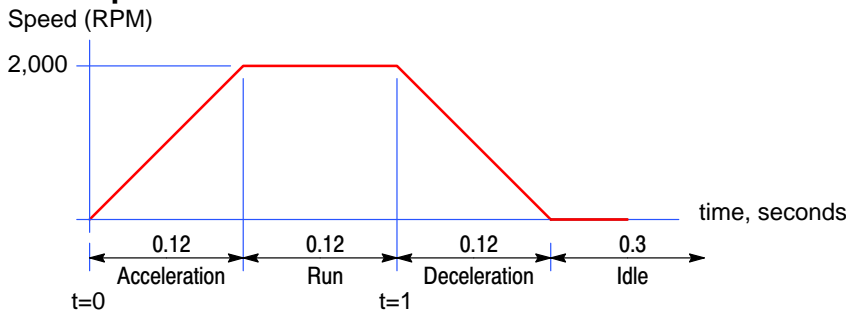

As friction and torque are overcome, the motor and load begin to accelerate. As the motor approaches the commanded speed, the error signal is reduced and, in turn, voltage applied to the motor is reduced. As the system stabilizes at running speed, only nominal power (voltage and current) are required to overcome friction. At t=1, the load approaches the desired position and begins to decelerate.

In applications with similar move profiles, most of the input energy is dissipated as heat. Therefore, in such systems, the motor's power dissipation capacity is the limiting factor. Thus, basic motor dynamics and power requirements must be determined to ensure adequate power capability for each motor.

Determining acceleration rate is the first step. For example, with a movement profile as shown in Figure 8, the acceleration rate can be determined from the speed and acceleration time. (Dividing the motor speed expressed in RPM by 9.55 converts the speed to radians per second.)

$$(21) \alpha_{acc} = \frac{S_m}{9.55t_{acc}} = \frac{2000}{9.55 \times 0.12} = 1745.2 \text{ rad./sec}^2$$

Acceleration torque

The torque required to accelerate the load and overcome mechanical friction is:

$$(22) T_{acc} = J_t(\alpha_{acc}) + T_f$$

$$(23) T_{acc} = (J_t + J_{ls} + J_m)(\alpha_{acc}) + T_f$$

Example: Our application requires moving a load with a leadscrew, Figure 6.

The load parameters are:

Weight of load (W_{lb}) = 200 lb leadscrew inertia (J_{ls}) = 0.00313 lb-in-sec², friction torque (T_f) = 0.95 lb-in acceleration rate (α_{acc}) = 1745.2 rad./sec².

Typical motor parameters are:

Motor inertia (J_m) = 0.0037 lb-in-s², continuous stall torque (T_s) = 14.4 lb-in, torque constant (K_t) = 4.8 lb-in/A and motor resistance (R_m) = 4.5 ohms.

Acceleration torque can be determined by substituting in Equation (23)

$$T_{acc} = (.00052 + .00313 + .0037)1745.2 + 0.95 = 13.77 \text{ lb-in.}$$

Duty cycle torque

In addition to acceleration torque, the motor must be able to provide sufficient torque over the entire duty cycle or move profile. This includes a certain amount of constant torque during the run phase, and a deceleration torque during the stopping phase. Running torque is equal to friction torque (T_f), in this case, 0.95 lb-in. During the stopping phase, deceleration torque is:

$$(24) T_{dec} = -J_t(\alpha_{acc}) + T_f = -(0.00052 + 0.00313 + 0.0037)1745.2 + 0.95 = -11.87 \text{ lb-in}$$

Now, the root mean squared (RMS) value of torque required over the move profile can be calculated:

$$(25) T_{RMS} = \sqrt{\frac{T_{acc}^2(t_{acc}) + T_{run}^2(t_{run}) + T_{dec}^2(t_{dec})}{t_{acc} + t_{run} + t_{dec} + t_{idle}}} = \sqrt{\frac{(13.77)^2(.12) + (.95)^2(.12) + (11.87)^2(.12)}{.12 + .12 + .12 + .3}} = 7.75 \text{ lb-in}$$

The motor selected for this application can supply a continuous stall torque of 14.4 lb-in, which is adequate for the application.

Control requirements

Determining a suitable control (amplifier) is the next step. The control must be able to supply sufficient accelerating current (I_{acc}), as well as continuous current (I_{RMS}) for the application's duty cycle requirements. Required acceleration current that must be supplied to the motor is:

$$(26) I_{acc} = \frac{T_{acc}}{K_t} = \frac{13.77}{4.8} = 2.86 \text{ A}$$

Current over the duty cycle, which the control must be able to supply to the motor, is:

$$(27) I_{RMS} = \frac{T_{RMS}}{K_t} = \frac{7.75}{4.8} = 1.61 \text{ A}$$

Power requirements

The control must supply sufficient power for both the acceleration portion of the movement profile, as well as for the overall duty cycle requirements. The two aspects of power requirements include:

- Power to move the load, “P_{del}” and
- Power losses dissipated in the motor, “P_{diss}”.

Power delivered to move the load is:

$$(28) P_{del} = \frac{T(S_m)(746)}{63,025}$$

Power dissipated in the motor is a function of the motor current. Thus, during acceleration, the value depends on the acceleration current (I_{acc}); and while running, it is a function on the RMS current (I_{RMS}). Therefore, the appropriate value is used in place of “I” in the following equation.

$$(29) P_{diss} = I^2(R_m)$$

The sum of these “P_{del}” and “P_{diss}” determine total power requirements.

Example: Power required during the acceleration portion of the movement profile can be obtained by substituting in Equations (8) and (9):

$$P_{del} = \frac{13.77(2,000)}{63,025}(746) = 325W$$

$$P_{diss} = (2.86)^2(4.5)(1.5) = 55W$$

$$P = P_{del} + P_{diss} = 325 + 55 = 380W$$

Note: The factor of 1.5 in the P_{diss} calculation is a factor used to make the motor’s winding resistance “hot.” This is a worst case analysis, assuming the winding is at 155 °C.

Continuous power required for the duty cycle is:

$$P_{del} = \frac{7.75(2,000)}{63,025}(746) = 183W$$

$$P_{diss} = (1.61)^2(4.5)(1.5) = 17W$$

$$P = P_{del} + P_{diss} = 183 + 17 = 200W$$

Summary

The control selected must be capable of delivering (as a minimum) an acceleration (or peak) current of 2.86 A, and a continuous (or RMS) current of 1.61 A. The power requirement calls for peak power of 380 W and continuous power of 200 W.

To aid in selecting both motors and controls (amplifiers), many suppliers offer computer software programs to perform the iterative calculations necessary to obtain the optimum motor and control.